



# 3.125Gbps XAUI Quad Equalizer

**MAX3980**

## General Description

The MAX3980 quad equalizer provides compensation for transmission medium losses for four “lanes” of digital NRZ data at a 3.125Gbps data rate in one package. It is tailor-made for 10-Gigabit Ethernet (10GbE) backplane applications requiring attenuation of noise and jitter that occur in communicating from MAC to PMD or from MAC to Switch. In support of the IEEE-802.3ae for the XAUI interface, the MAX3980 adaptively allows XAUI lanes to reach up to 40in (1.0m) on FR4 board material.

The equalizer has 100Ω differential CML data inputs and outputs.

The MAX3980 is available in a 44-pin exposed-pad QFN package. The MAX3980 consumes only 700mW at +3.3V or 175mW per channel.

## Applications

- IEEE-802.3ae XAUI Interface (3.125Gbps)
- InfiniBand (2.5Gbps)

## Features

- ◆ Four Differential Digital Data “Lanes” at 3.125Gbps
- ◆ Spans 40in (1.0m) of FR4 PC Board
- ◆ Receiver Equalization Reduces Intersymbol Interference (ISI)
- ◆ Low-Power, 175mW per Channel
- ◆ Standby Mode—Power-Down State
- ◆ Single +3.3V Supply
- ◆ Signal Detect

## Ordering Information

PART	TEMP. RANGE	PIN-PACKAGE
MAX3980UGH	0°C to +85°C	44 QFN-EP*

\*Exposed pad

Pin Configuration appears at end of data sheet.

## Typical Application Circuit

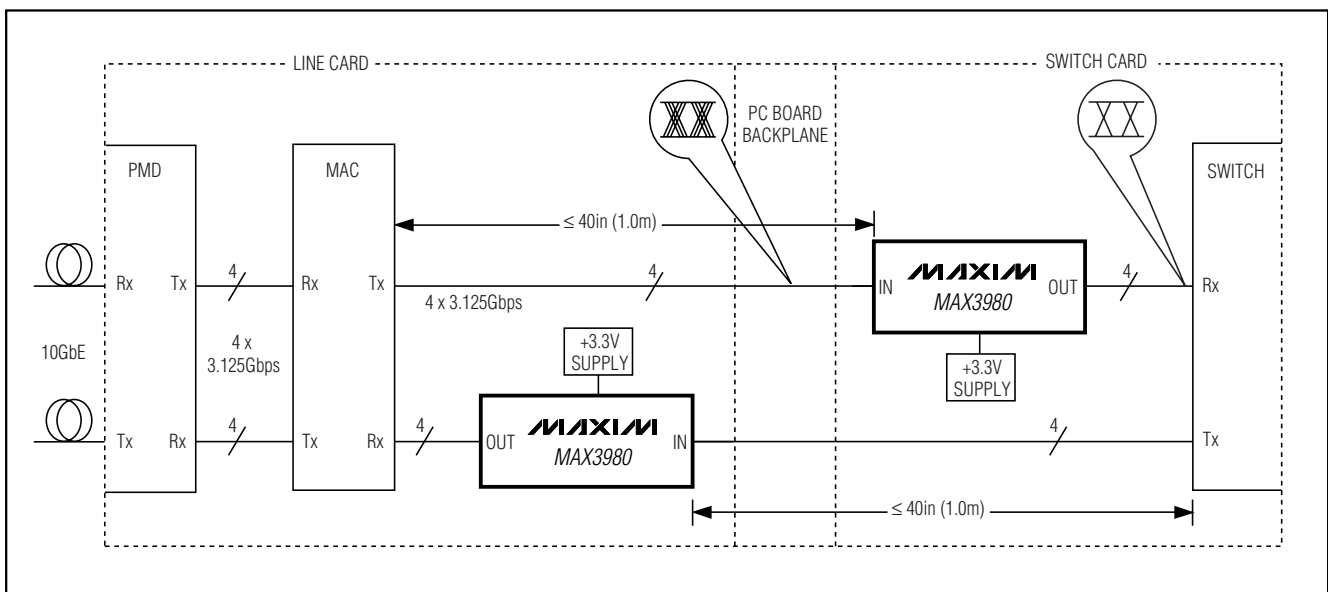

## 3.125Gbps XAUI Quad Equalizer

### ABSOLUTE MAXIMUM RATINGS

Supply Voltage,  $V_{CC}$ .....-0.5V to +4.0 V  
 Voltage at SDET,  $IN_{\pm}$  .....+0.5V to ( $V_{CC} + 0.5V$ )  
 Current Out of  $OUT_{\pm}$ .....-25mA to +25mA  
 Continuous Power Dissipation ( $T_A = +85^{\circ}C$ )  
 44-Pin QFN-EP (derate 26.3mW/ $^{\circ}C$  above +85 $^{\circ}C$ )...2105mW

Operating Ambient Temperature Range .....0 $^{\circ}C$  to +85 $^{\circ}C$   
 Storage Temperature Range .....-55 $^{\circ}C$  to +150 $^{\circ}C$   
 Lead Temperature (soldering, 10s) .....+300 $^{\circ}C$

Stresses beyond those listed under "Absolute Maximum Ratings" may cause permanent damage to the device. These are stress ratings only, and functional operation of the device at these or any other conditions beyond those indicated in the operational sections of the specifications is not implied. Exposure to absolute maximum rating conditions for extended periods may affect device reliability.

### ELECTRICAL CHARACTERISTICS

( $V_{CC} = +3.0V$  to +3.6V, input data rate = 3.125Gbps,  $T_A = 0^{\circ}C$  to +85 $^{\circ}C$ . Typical values are at  $V_{CC} = +3.3V$  and  $T_A = +25^{\circ}C$ , unless otherwise noted.)

PARAMETER	SYMBOL	CONDITIONS	MIN	TYP	MAX	UNITS
Supply Power		EN = TTL low			0.25	W
		EN = TTL high		0.7	0.9	
Supply Noise Tolerance		10Hz < f < 100Hz		100		mVp-p
		100Hz < f < 1MHz		40		
		1MHz < f < 2.5GHz		10		
Signal Detect Assert		Input signal level to assert SDET (Note 1)	100			mVp-p
Signal Detect Deassert		Input signal level to deassert SDET (Note 1)			30	mVp-p
Signal Detect Delay					10	$\mu s$
Latency		From input to output		0.32		ns
<b>CML RECEIVER INPUT</b>						
Input Voltage Swing		XAUI transmitter output measured differentially at point A, Figure 1, using K28.5 pattern	200		800	mVp-p
Return Loss		100MHz to 2.5GHz		12		dB
Input Resistance		Differential	80	100	120	$\Omega$
<b>EQUALIZATION</b>						
Residual Jitter		Total jitter (Note 2)			0.3	Ulp-p
		Deterministic jitter			0.2	
Random Jitter		(Note 2)		1.5		psRMS
<b>CML TRANSMITTER OUTPUT (into 100<math>\Omega \pm 1\Omega</math>)</b>						
Output Voltage Swing		Differential swing	550		850	mVp-p
Common-Mode Voltage				$V_{CC} - 0.3$		V
Transition Time	$t_f, t_r$	20% to 80% (Note 3)		60	130	ps
Differential Skew		Difference in 50% crossing between $OUT_{+}$ and $OUT_{-}$			12	ps
Output Resistance		Single ended	40	50	60	$\Omega$

# 3.125Gbps XAUI Quad Equalizer

## ELECTRICAL CHARACTERISTICS (continued)

(V<sub>CC</sub> = +3.0V to +3.6V, input data rate = 3.125Gbps, T<sub>A</sub> = 0°C to +85°C. Typical values are at V<sub>CC</sub> = +3.3V and T<sub>A</sub> = +25°C, unless otherwise noted.)

PARAMETER	SYMBOL	CONDITIONS	MIN	TYP	MAX	UNITS
<b>TTL CONTROL PINS</b>						
Input High Voltage			2.0			V
Input Low Voltage					0.8	V
Input High Current					250	μA
Input Low Current					500	μA
Output High Voltage		Internal 10kΩ pullup	2.4			V
Output Low Voltage		Internal 10kΩ pullup			0.4	V

**Note 1:** K28.7 pattern is applied differentially at point A as shown in Figure 1.

**Note 2:** Total jitter does not include the signal source jitter. Total jitter (TJ) = [14.1 × RJ + DJ] where RJ is random RMS jitter and DJ is maximum deterministic jitter. Signal source is a K28.5± pattern (**00 1111 1010 11 0000 0101**) for the deterministic jitter test and K28.7 (**0011111000**) or equivalent for the random jitter test. Residual jitter is that which remains after equalizing media-induced losses of the environment of Figure 1 or its equivalent. The deterministic jitter at point B must be from media-induced loss and not from clock-source modulation. Jitter is measured at 0 at point C of Figure 1.

**Note 3:** Using K28.7 (**0011111000**) pattern.

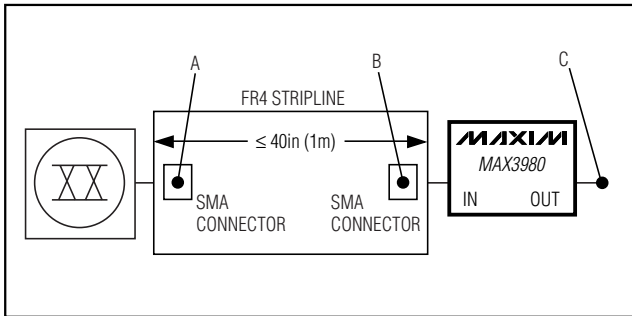

Figure 1. Test Conditions Referenced in the Electrical Characteristics Table

# 3.125Gbps XAUI Quad Equalizer

## Typical Operating Characteristics

( $V_{CC} = +3.3V$ , 3.125Gbps, 500mVp-p board input with  $2^7 - 1$  PRBS,  $T_A = +25^\circ C$ , unless otherwise noted.)

**EQUALIZER INPUT EYE DIAGRAM  
BEFORE EQUALIZATION  
(40in FR4 6mil STRIPLINE)**

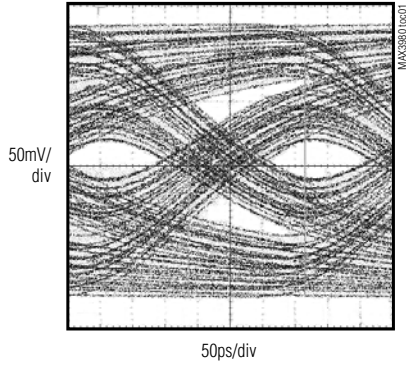

**EQUALIZER OUTPUT EYE DIAGRAM  
AFTER EQUALIZATION  
(40in FR4 6mil STRIPLINE)**

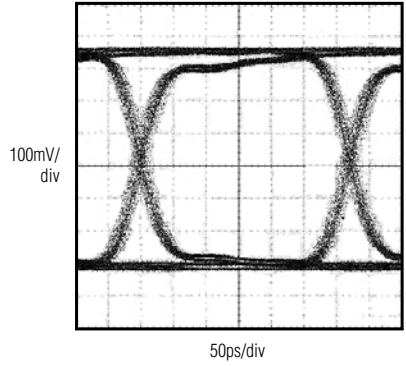

**EQUALIZER OUTPUT EYE DIAGRAM  
(20in BACKPLANE WITH TWO TERADYNE HSD  
CONNECTORS AND 3in DAUGHTERBOARD)**

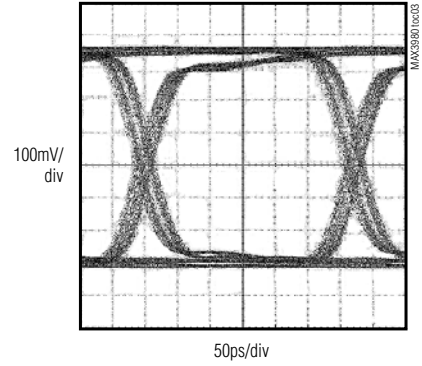

**INPUT RETURN GAIN (S11, DIFFERENTIAL,  
INPUT SIGNAL = -60dBm,  
DEVICE POWERED OFF)**

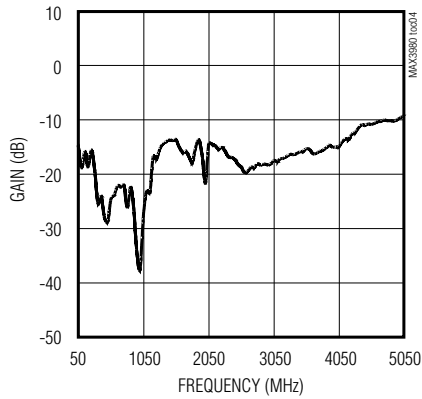

**EQUALIZER DETERMINISTIC JITTER  
vs. LENGTH  
(FR4 6mil STRIPLINE, K28.5 PATTERN)**

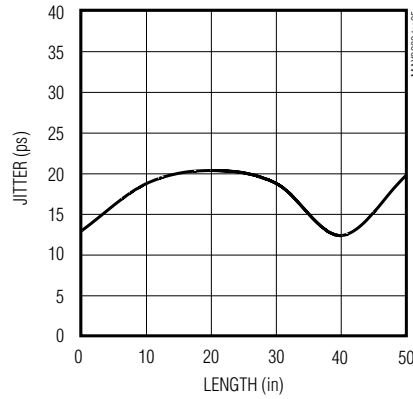

**EQUALIZER LATENCY  
vs. TEMPERATURE**

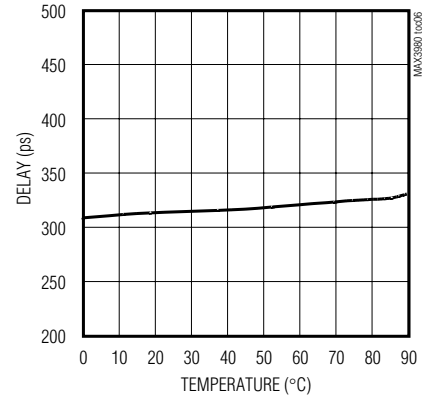

**EQUALIZER OPERATING  
CURRENT vs. TEMPERATURE**

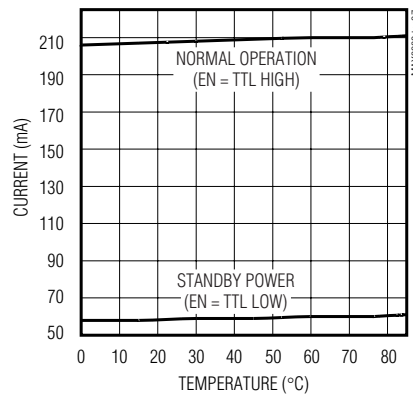

## 3.125Gbps XAUI Quad Equalizer

### Pin Description

**MAX3980**

PIN	NAME	FUNCTION
1, 5, 9, 13, 23, 27, 31, 35	VCC	+3.3V Supply Voltage
2	IN1+	Positive Equalizer Input Channel 1, CML
3	IN1-	Negative Equalizer Input Channel 1, CML
4, 8, 12, 16, 26, 30, 34, 38	GND	Supply Ground
6	IN2+	Positive Equalizer Input Channel 2, CML
7	IN2-	Negative Equalizer Input Channel 2, CML
10	IN3+	Positive Equalizer Input Channel 3, CML
11	IN3-	Negative Equalizer Input Channel 3, CML
14	IN4+	Positive Equalizer Input Channel 4, CML
15	IN4-	Negative Equalizer Input Channel 4, CML
17–22, 39–42	N.C.	No Connection. Leave unconnected.
24	OUT4-	Negative Equalizer Output Channel 4, CML
25	OUT4+	Positive Equalizer Output Channel 4, CML
28	OUT3-	Negative Equalizer Output Channel 3, CML
29	OUT3+	Positive Equalizer Output Channel 3, CML
32	OUT2-	Negative Equalizer Output Channel 2, CML
33	OUT2+	Positive Equalizer Output Channel 2, CML
36	OUT1-	Negative Equalizer Output Channel 1, CML
37	OUT1+	Positive Equalizer Output Channel 1, CML
43	EN	Enable Equalizer Input. A TTL high selects normal operation. A TTL low selects low-power standby mode.
44	SDET	Signal Detect Output for Channel 1. Produces a TTL high output when a signal is detected.
EP	Exposed Pad	Ground. The exposed pad must be soldered to the circuit board ground plane for proper thermal and electrical performance.

## 3.125Gbps XAUI Quad Equalizer

### Functional Diagram

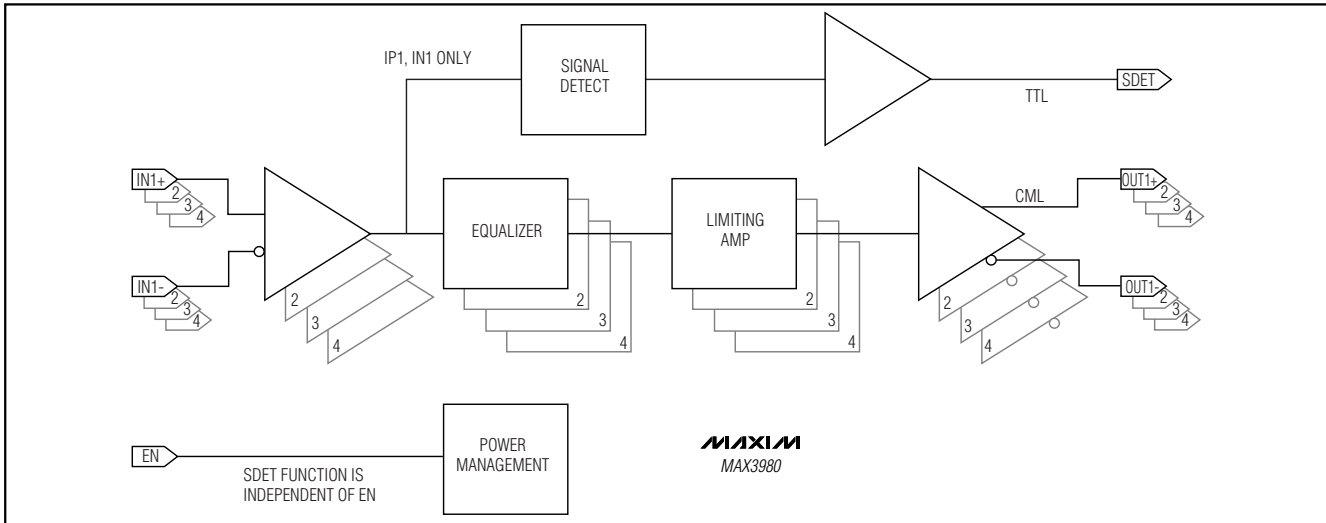

### Detailed Description

#### Receiver and Transmitter

The receiver accepts four lanes of 3.125Gbps current-mode logic (CML) digital data signals. The adaptive equalizer compensates each received signal for dielectric and skin losses. The limiting amp shapes the output of the equalizer. The regenerated XAUI lanes are transmitted as CML signals. The source impedance and termination impedances are 100Ω differential.

#### General Theory of Operation

Internally, the MAX3980 comprises signal-detect circuitry, four matched equalizers, and one equalizer-control loop. The four equalizers are made up of a master equalizer and three slave equalizers. The adaptive control is generated from only channel 1. It is assumed that all channels have the same characterization in frequency content, coding, and transmission length.

The master equalizer consists of the following functions: signal detect, adaptive equalizer, equalizer control, and limiting and output drivers. The signal detect indicates input signal power. When the input signal level is sufficiently high, the SDET output is asserted. This does not directly control the operation of the part.

The equalizer core reduces intersymbol interference (ISI), compensating for frequency-dependent, media-induced loss. The equalization control detects the spectral contents of the input signal and provides a control voltage to the equalizer core, adapting it to different media. The equalizer operation is optimized for

short-run DC-balanced transmission codes such as 8b/10b codes.

#### CML Input and Output Buffers

The input and output buffers are implemented using CML. Equivalent circuits are shown in Figures 2 and 3. For details on interfacing with CML, see Maxim application note HFAN-1.0, *Interfacing Between CML, PECL, and LVDS*. The common-mode voltage of the input and output is above 2.5V. AC-coupling capacitors are required when interfacing this part. Values of 0.10μF or greater are recommended.

#### Media Equalization

Equalization at the input port compensates for the high-frequency loss encountered with up to 40in (1.0m) of FR4 transmission lines. This part is optimized for 40in and 3.125Gbps; however, the part reduces ISI for signals spanning longer distances and functions for data rates from 2Gbps to 4Gbps, provided that short-length balanced codes, such as 8b/10b, are used.

### Applications Information

#### Standby Mode

The power-saver standby state allows reduced-power operation. The TTL input, EN, must be set to TTL high for normal operation. A TTL low at EN forces the equalizer into the standby state. The signal EN does not affect the operation of the signal detect (SDET) function. For constant operation, connect the EN signal directly to VCC.

# 3.125Gbps XAUI Quad Equalizer

**MAX3980**

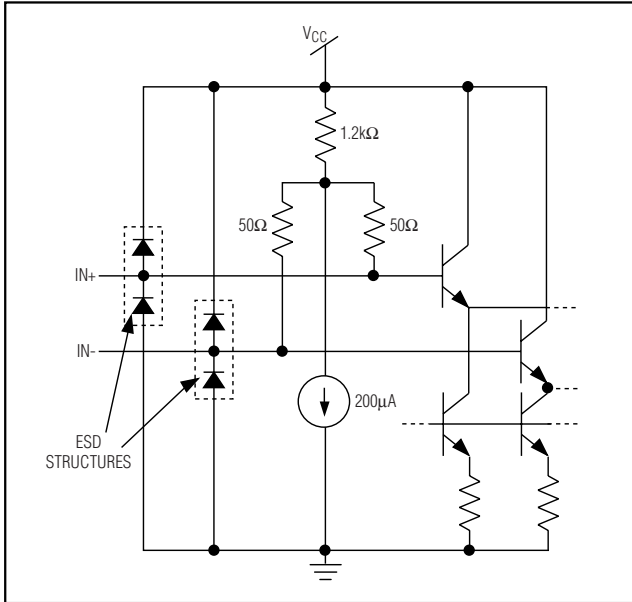

Figure 2. CML Input Buffer

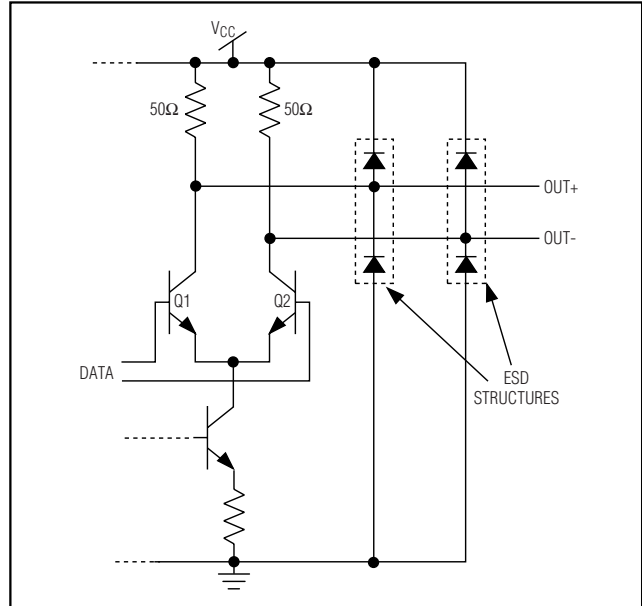

Figure 3. CML Output Buffer

## Signal Detect with Standby Mode

Signal activity is detected on channel 1 only. When the peak-to-peak differential voltage at IN1± is less than 30mVp-p, the TTL output SDET goes low. When the peak-to-peak differential voltage becomes greater than 100mVp-p, SDET is asserted high. SDET can be used to automatically force the equalizer into standby mode by connecting SDET directly to the EN input. When not used, SDET should not be connected.

The signal-detect function continues to operate while the part is in standby mode. While connected to the EN pin, the signal detect can “wake up” the part and resume normal operation.

## Layout Considerations

Circuit-board layout and design can significantly affect the MAX3980 performance. Use good high-frequency design techniques, including minimizing ground inductances and vias and using controlled-impedance transmission lines for the high-frequency data signals. Signals should be routed differentially to reduce EMI susceptibility and crosstalk. Power-supply decoupling capacitors should be placed as close as possible to the VCC pins.

## Pin Configuration

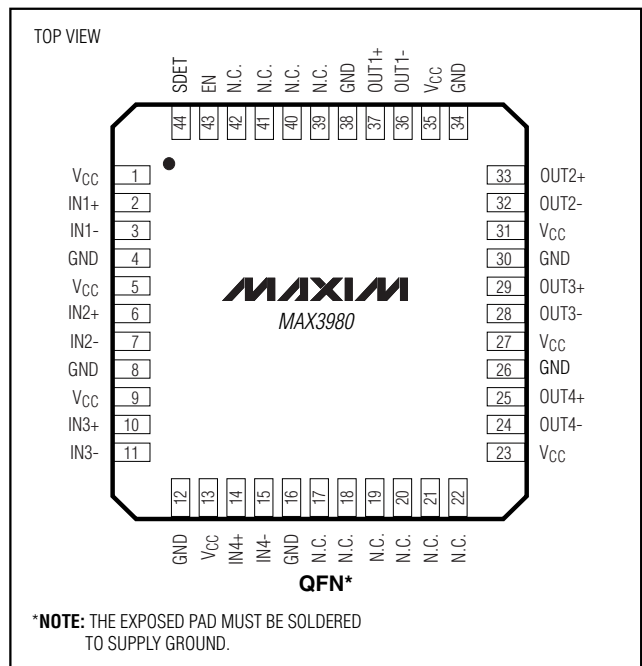





# 3.125Gbps XAUI Quad Equalizer

## Package Information (continued)

MAX3980

### NOTES:

1. DIE THICKNESS ALLOWABLE IS 0.305mm MAXIMUM(.012 INCHES MAXIMUM)
2. DIMENSIONING & TOLERANCES CONFORM TO ASME Y14.5M. - 1994.
3. N IS THE NUMBER OF TERMINALS.  
Nd IS THE NUMBER OF TERMINALS IN X-DIRECTION &  
Ne IS THE NUMBER OF TERMINALS IN Y-DIRECTION.
4. DIMENSION b APPLIES TO PLATED TERMINAL AND IS MEASURED BETWEEN 0.20 AND 0.25mm FROM TERMINAL TIP.
5. THE PIN #1 IDENTIFIER MUST EXIST ON THE TOP SURFACE OF THE PACKAGE BY USING INDENTATION MARK OR INK/ LASER MARKED. OF PACKAGE BODY.
6. EXACT SHAPE AND SIZE OF THIS FEATURE IS OPTIONAL.
7. ALL DIMENSIONS ARE IN MILLIMETERS.
8. PACKAGE WARPAGE MAX 0.08mm.
9. APPLIED FOR EXPOSED PAD AND TERMINALS.  
EXCLUDE EMBEDDED PART OF EXPOSED PAD FROM MEASURING.
10. MEETS JEDEC MO220.
11. THIS PACKAGE OUTLINE APPLIES TO ANVIL SINGULATION (STEPPED SIDES) AND TO SAW SINGULATION (STRAIGHT SIDES) QFN STYLES.

SYMBOL	COMMON DIMENSIONS			N <sub>TER</sub>
	MIN.	NOM.	MAX.	
A	0.80	0.90	1.00	
A1	0.00	0.01	0.05	
A2	0.00	0.65	1.00	
A3	0.20 REF.			
D	7.00 BSC			
D1	6.75 BSC			
E	7.00 BSC			
E1	6.75 BSC			
θ	0°		12°	
P	0		0.60	
D2	2.25	—	5.25	
E2	2.25	—	5.25	

SYMBOL	PITCH VARIATION C			N <sub>TER</sub>	SYMBOL	PITCH VARIATION C			N <sub>TER</sub>	SYMBOL	PITCH VARIATION D			N <sub>TER</sub>
	MIN.	NOM.	MAX.			MIN.	NOM.	MAX.			MIN.	NOM.	MAX.	
ⓐ	0.65 BSC			3	ⓐ	0.50 BSC			3	ⓐ	0.50 BSC			3
N	32			3	N	44			3	N	48			3
Nd	8			3	Nd	11			3	Nd	12			3
Ne	8			3	Ne	11			3	Ne	12			3
L	0.35	0.55	0.75		L	0.35	0.55	0.75		L	0.30	0.40	0.50	
b	0.23	0.28	0.35	4	b	0.18	0.23	0.30	4	b	0.18	0.23	0.30	4

<b>MAXIM</b>			
PROPRIETARY INFORMATION			
TITLE: PACKAGE OUTLINE, 32,44,48L QFN, 7x7x0.90 MM			
APPROVAL	DOCUMENT CONTROL NO.	REV	2/2
	21-0092	F	

Maxim cannot assume responsibility for use of any circuitry other than circuitry entirely embodied in a Maxim product. No circuit patent licenses are implied. Maxim reserves the right to change the circuitry and specifications without notice at any time.

Maxim Integrated Products, 120 San Gabriel Drive, Sunnyvale, CA 94086 408-737-7600 \_\_\_\_\_ 9